

Child Protection Seat

KB102-00 Cream

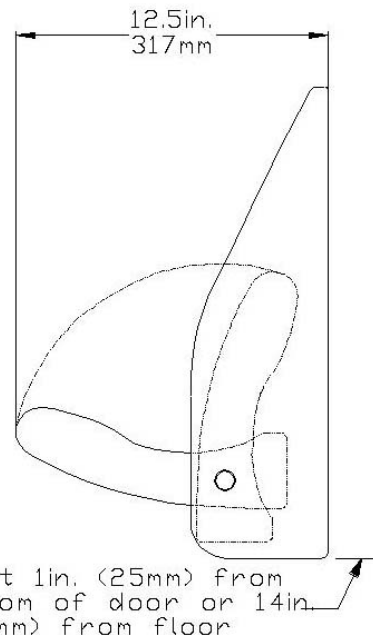

7881 S. Wheeling Court
Englewood, CO 80112
Toll free: 1-888-733-3456
Fax: 303-539-8399
www.koalabear.com

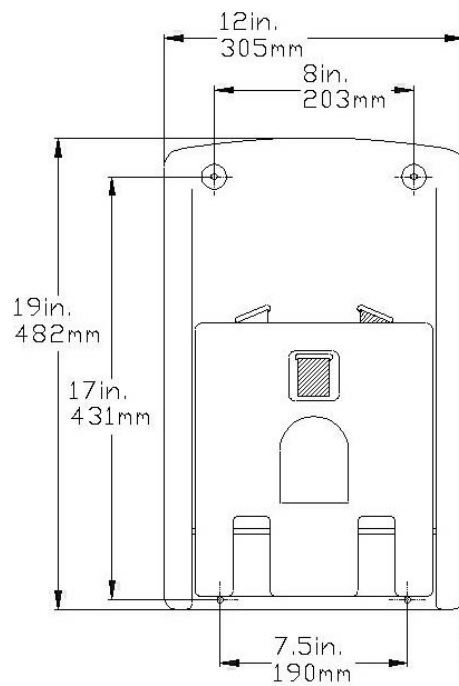



ADA Compliance

(when properly installed)
4.4.1 Max. Protruding Objects
4.2.5 Forward Reach
4.2.6 Parallel Approach
4.27.4 Operation

FDA approved blow-molded high-density polyethylene. Stainless steel hinge rod. Textured seat surface with nylon safety straps that extend over child's shoulders and between legs for security.

OPERATION

Designed to mount on the wall of a restroom stall, vanity sink area, or a dressing room. Closed unit folds to less than 6 inches, and requires less than 2 square feet of wall space. FDA approved high-density polyethylene is easy to clean and resists fungal and bacterial growth. Can withstand static loads of 150 pounds (68 kilos).

Warning: To insure that the unit supports the intended loads, seat must be properly installed according to the manufacturer's instructions.

INSTALLATION:

To insure proper installation and compliance with building codes, it is recommended that a qualified person or carpenter perform the installation of the unit. Koala Bear Kare® Child Protection Seats have been tested to hold a static load of up to 150 pounds. To do this, the unit must be properly installed onto a permanent wall or restroom stall wall that is capable of supporting that much weight and can accommodate the supplied installation hardware (or other suitable hardware if unit is to be installed on another type of wall).

Drilling holes and mounting the Child Protection Seat:

1. Remove the unit from the shipping container and check for any freight damage. Identify the best location for installing the Child Protection Seat. Hold the unit in place, open the seat, and make sure that there is adequate operating clearance. Use the seat as a template for locating the four mounting holes onto the mounting surface. Put bottom holes 1" from bottom of wall or 14" from the floor, whichever is higher.
2. The Child Protection Seat has four mounting holes provided in the back wall of the unit, which are positioned 8" apart horizontally and 17" apart vertically. Hardware included with unit is intended for installation of seat to restroom stall or fitting room wall.
3. Drill four 3/8" holes through the wall.
4. Insert the four threaded plugs with head holes (supplied) from the outside of the wall.
5. Mount the Child Protection Seat with the four 1/4" screws and washers (supplied).

SPECIFICATION:

Child Protection Seat body shall be durable, high-impact polyethylene. Design of unit shall be surface-mounted. Seat shall be secured to back plate with a concealed, full-length stainless steel hinge rod with steel bushings embedded in the plastic. No hinge structure shall be exposed on interior or exterior surfaces. Seat shall have nylon safety straps. Unit shall support loads of up to 150 lbs (68 kg) when properly installed. Manufacturer's service and parts manual shall be provided to the building owner/manager upon completion of project. Unit shall be backed by a 5-year manufacturers limited warranty and manufactured in the U.S.A.

**Child Protection Seat shall be model KB102-00 of Koala Kare Products, A Division of Bobrick
7881 South Wheeling Court, Englewood, CO 80112, Tel: 1-888-733-3456, Web: www.koalabear.com**